

## Parameters

Electrical Parameters:	
Working voltage	DC15 - 30V
Buspro power consumption	25mA/DC24V
Illumination detection rang	0-300 Lux
Communication	HDL Buspro
Buspro terminal	CAT5 or ACT5e
Environmental Conditions:	
Working temperature	-5°C~45°C
Working relative humidity	Up to 90%
Storage temperature	-20°C~+60°C
Storage relative humidity	Up to 93%
Approved	
CE	
RoHS	
Product Information:	
Dimensions	80(D)×32 ( mm )
Weight	86.5g
Housing material	ABS
Installation	Ceiling mounted
IP Protection	IP20

## HDL Buspro Definition for Ca-

HDL Buspro	CAT5 or CAT5E
DC24V	Brown/Orange
COM	Brown White/Orange White
DATA-	Blue White/Green White
DATA+	Blue/Green

## Important Notes

- Air quality detection: cigarettes, cooking odors, hydrogen, carbon monoxide, ethanol, isobutene, alcohol.
- Buspro cable — CAT5 or CAT5E.
- Buspro connection — Series connection (hand-in-hand).
- Installation — Indoor and ceiling-mount.

## Overview



SB-CMS-LA air quality sensor is a multi-function control module. It can measure air quality and brightness, and control targets according the values of lux, dry contact and universal switch.

## Functions

- Embedded lux sensor, air quality sensor, air comprehensive index sensor, 2-Dry Contact inputs, 2 universal switch inputs, 1 logic block status input.
- 2 logic relations: OR, AND.
- Up to 24 logic blocks, maximum 7 logic inputs conditions available, each logic block can control up to 20 different control targets.
- Security function, to be used with the security module.
- Real formulation for brightness and air comprehensive index.

## Dimensions and Wiring

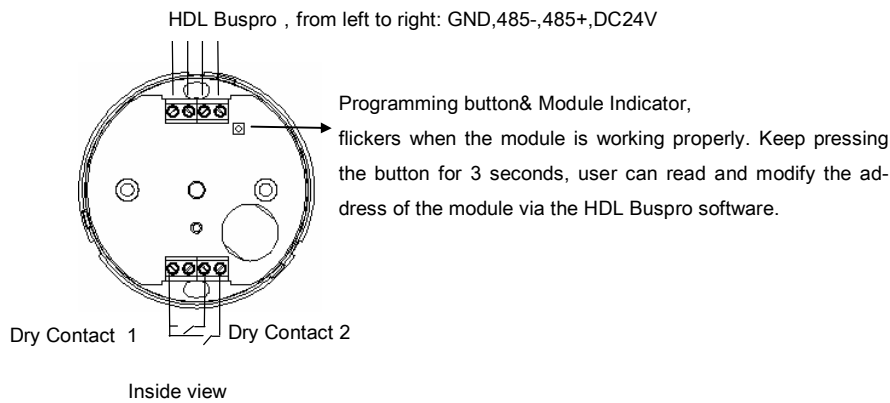
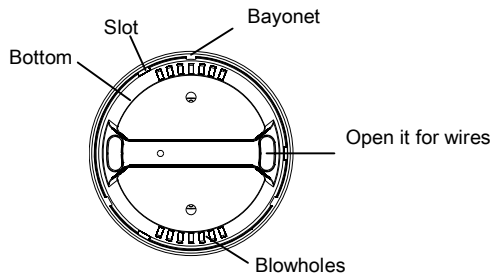
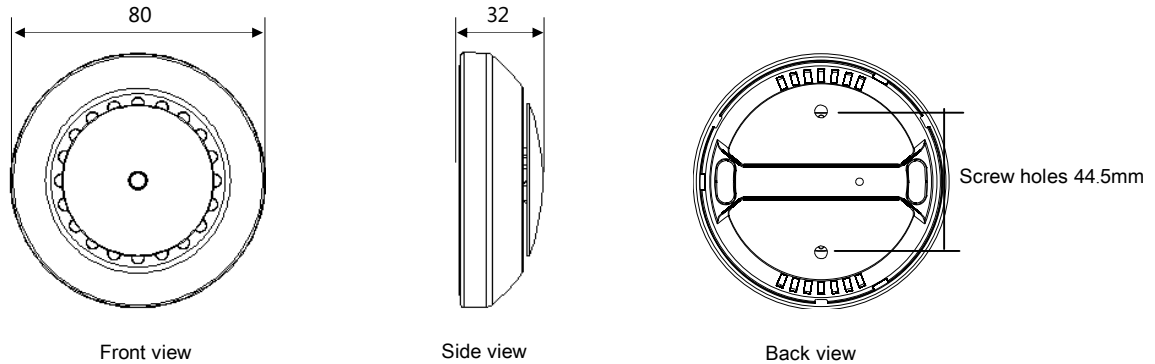

## Safety Precautions

- The screw down strength should not exceed 0.4Nm.
- Do not make wrong connection on Buspro interface, it will damage the Buspro interface of this module.
- Avoid contact with the rain or water module, it will damage this device.
- Do not get AC power into Buspro wire , it will damage all devices in the system.
- Avoid contact with liquids and corrosive gases.

## Packing List

- |                                  |    |
|----------------------------------|----|
| ■ Datasheet                      | x1 |
| ■ Air quality sensor (SB-CMS-LA) | x1 |